

## GMD20 Series Carbon Dioxide Transmitters for Demand Controlled Ventilation Applications



*The GMD20 series transmitters are designed for use in ventilation-related applications.*

### Features/Benefits

- Versatile transmitters
- Reliable measurement with sensor inside the duct
- Incorporates Vaisala CARBOCAP® Sensor - the silicon-based NDIR sensor
- Excellent long-term stability
- Negligible temperature dependence
- Ease of installation

The duct mounted Vaisala CARBOCAP® Carbon Dioxide Transmitter Series GMD20 is specially designed for Demand Controlled Ventilation (DCV). They are easy to install and require no maintenance. The recommended calibration interval is five years.

### Vaisala CARBOCAP® Technology

The GMD20 Series Transmitters use the silicon-based Vaisala CARBOCAP® Sensor. The simple structure and reference measurement capabilities make this Single-Beam, Dual-Wavelength NDIR sensor extremely stable and reliable.

The temperature and flow dependences of the sensor are negligible. In addition, the measurement accuracy is not affected by dust, water vapor and most chemicals.

### Versatile Transmitters

The GMD20 series transmitters can be used independently, or incorporated into building energy management systems. The series consists of duct mount units GMD20 and GMD20D. Version D has a display. The duct units' compact sensor head design fits inside the ventilation duct, eliminating the risk of leaking gaskets and measurement errors.

In addition to the standard 0 ... 20 mA, 4 ... 20 mA and 0 ... 10 V outputs, there are two other options: one LonWorks® interface and a relay output. The relay output is standard with the display units.

### Improve Indoor Air at Minimal Energy Costs

The use of the GMD20 series transmitters ensures the best possible control of air quality and results in considerable savings in energy consumption, maintenance and recalibration costs.

# Technical Data

## Performance

### CARBON DIOXIDE MEASUREMENT

Measurement range	0 ... 2000 ppm
	(nominal; can be calibrated for other ranges: 0 ... 5000 ppm, 0 ... 10,000 ppm, 0 ... 20,000 ppm)
Accuracy (including repeatability, non-linearity and calibration uncertainty)	± (2 % of range + 2% of reading)
Long-term stability	<±5 % of range / 5 years
Response time (63%)	1 minute
Warm-up time	1 minute, 15 minutes full specifications

## Inputs and Outputs

Outputs	0 ... 20 or 4 ... 20 mA and 0 ... 10 V
Optional outputs	relay LonWorks® interface
Resolution of analog outputs	8 bits
Recommended external load:	
current output	max. 500 ohm
voltage output	min. 1 kohm
Operating voltage	nominal 24 VAC/DC (18 ... 30 VDC)
Connections	screw terminals, wire size 0.5 ... 1.5 mm <sup>2</sup>
Power consumption	<2.5 W

## Operating Environment

Temperature	-5 ... +45 °C (+23 ... +113 °F)
Humidity	0 ... 85 %RH, non-condensing
Flow velocity (GMD20)	0 ... 10 m/s
Electromagnetic compatibility	EN61326-1, Generic Environment

## Mechanics

Housing material	ABS plastic
Housing classification (GMD20 electronics housing)	IP65
Weight: GMD20 (D)	140 g (170 g)

## Accessories and Options

Display and relay option for GMD20	GMI21
Relay output option	GMR20
LonWorks® module with CO <sub>2</sub> signal (Not available when display option is added)	GML20
Serial COM adapter	19040GM
Hand-held meter for field verification	GM70

## Dimensions

Dimensions in mm

GMD20 and GMD20D

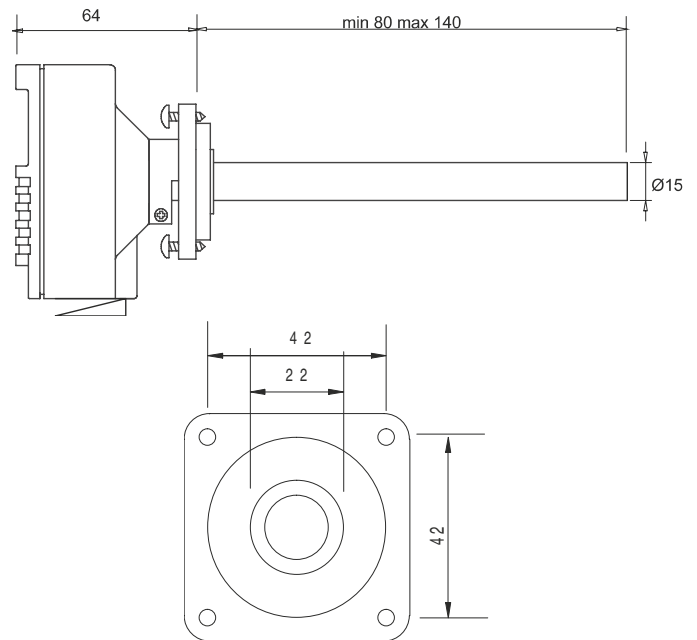

CARBOCAP® is a registered trademark of Vaisala.

# VAISALA

详情请访问：[www.system-instruments.com](http://www.system-instruments.com)  
电话：0756-2127068  
授权代理商：珠海赛思特仪表设备有限公司



Scan the code for more information

Ref. B211432EN-B ©Vaisala 2015

This material is subject to copyright protection, with all copyrights retained by Vaisala and its individual partners. All rights reserved. Any logos and/or product names are trademarks of Vaisala or its individual partners. The reproduction, transfer, distribution or storage of information contained in this brochure in any form without the prior written consent of Vaisala is strictly prohibited. All specifications — technical included — are subject to change without notice.

